

New Product Solutions

A useful tip showing ITW Shakeproof Industrial's ability to provide fastening solutions.

Hurricane Rite Screw™

With ITW Shakeproof Tapered Lead

New High-Performance Fastener for Thin Gauge Applications

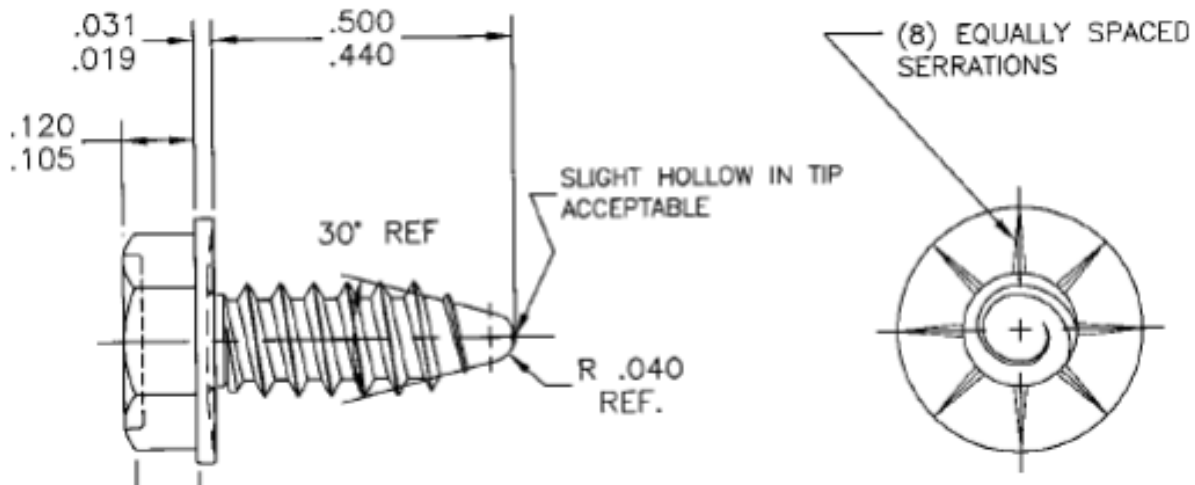

A ROBUST DESIGN THAT IS THE ONLY SOLUTION WHOSE PERFORMANCE HAS BEEN PROVEN TO ELIMINATE STRIP-OUT PROBLEMS CAUSED FROM THIN SHEET METAL AND MISALIGNED HOLES.

- Material thickness 50% less than needed for standard “AB”.
- Eliminates stripping problems in materials as thin as .025”.
- Solve Misalignment issues that cause stripping.
- Part number consolidation of “AB, “B”, sharp points and blunt points.
- Due to radius point, it is safe for use around wires
- Ergonomically safe for workers, no scratched skin from sharp points.
- Hole size standardization across various tapping thicknesses.
- Eliminate rework cost due to stripped screws or work piece scarring.
- Superior locking action of the Hurricane ribs allow you to reduce screw size and maintain high performance