

# **ITW** Shakeproof

## New Product Solutions

A useful tip showing Shakeproof's ability to provide fastening solutions.

### **Hurricane Rite Screw™** With ITW Shakeproof Tapered Lead

New High Performance Fastener for Thin Gauge applications.

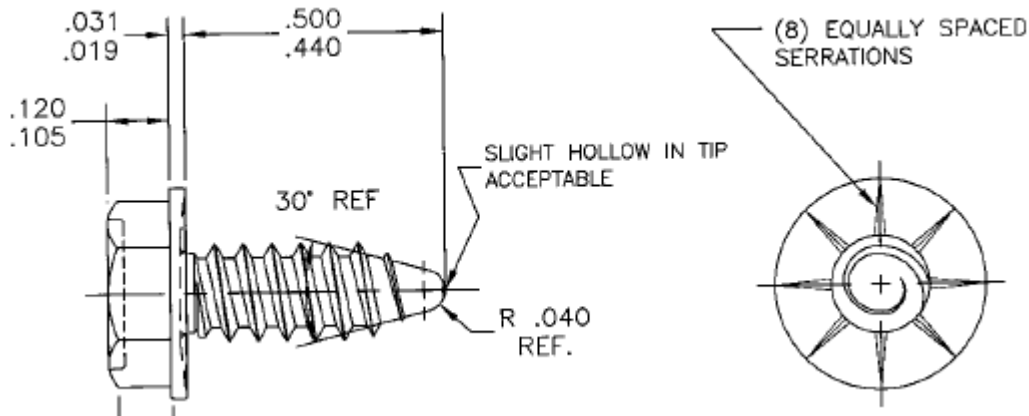

**A ROBUST DESIGN THAT IS THE ONLY SOLUTION WHOSE PERFORMANCE HAS BEEN PROVEN TO ELIMINATE STRIP-OUT PROBLEMS CAUSED FROM THIN SHEET METAL AND MISALIGNED HOLES.**

- Material thickness 50% less than needed for standard "AB".
- Eliminates stripping problems in materials as thin as .025".
- Solve Misalignment issues that cause stripping.
- Part number consolidation of "AB, "B", sharp points and blunt points.
- Meets UL requirements of no sharp points around wires.
- Ergonomically safe for workers, no scratched skin from sharp points.
- Hole size standardization across various tapping thicknesses.
- Eliminate rework cost due to stripped screws or work piece scarring.
- Superior locking action of the Hurricane ribs allow you to reduce screw size and maintain high performance.

For more information, please contact Sales Engineer Dennis W Mulvey  
[dennis.mulvey@shakeproofgroup.com](mailto:dennis.mulvey@shakeproofgroup.com)

**ITW** Shakeproof

Phone 630-605-1444 /Fax 815-623-5147